

# 25'

## GUARDIAN™



### STANDARD FEATURES:

- Unsinkable hull with commercial-grade fiberglass laminate
- Self-bailing hull with scuppers
- Haze grey gelcoat
- Heavy-duty rub rail
- Black identification and trim markings
- Fiberglass G3 console with storage area, dome light, windshield and grab rail
- 36" heavy-duty aluminum leaning post with lockable door, shelf and grab rail
- Padded stainless steel steering wheel
- Hydraulic steering
- Anchor locker with fiberglass cover
- In-deck bow storage with bilge pump / float
- Forward belowdeck storage compartment with aluminum hatch
- Bow eye / lifting eye
- Stern eyes
- 30" transom
- 10" cleats (5)
- Navigation lights
- Fire extinguisher
- Bilge pumps with automatic float switches (2)
- Switch panel – bilge (2), navigation lights and auxiliary (4)
- 159-gallon baffled aluminum fuel tank
- 10-year limited hull warranty

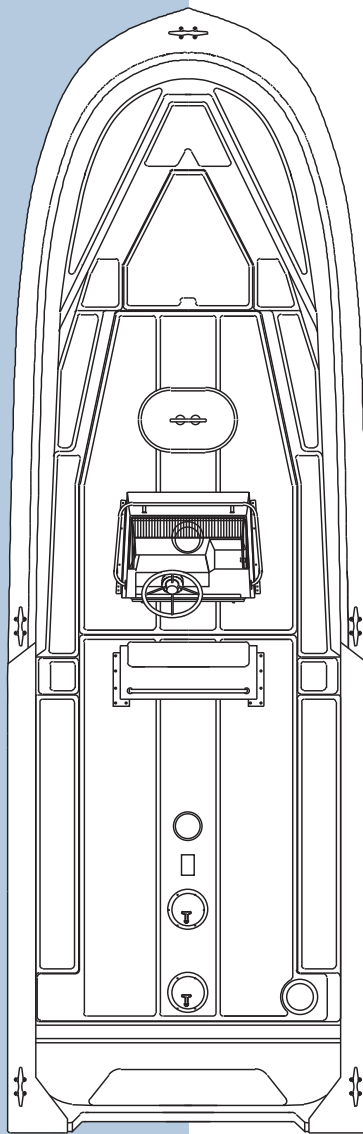

### SPECIFICATIONS:

• LOA	24' 7"	7.49 m
• Beam	8'	2.43 m
• Draft	16"	.40 m
• Weight	3575 lbs	1621 kg
• Max Weight	3035 lbs	1376 kg
• Swamped Capacity	7000 lbs	3175 kg
• Person Capacity	12	
• Max Horsepower	300 hp	223 kw
• Min Horsepower	115 hp	85 kw
• Max Engine Weight	1060 lbs	480 kg
• Transom Height	30"s / 25"d	.76 m / .63 m
• Fuel Capacity	159 gal	601 L
• Bridge Clearance	96"	2.43 m

*Bridge clearance is measured from the waterline to the highest point of the base boat. Specified measurements are approximations and subject to variance.*



**BUILT FOR THE MISSION.™**